



A Hand Dryer solution for every project and every budget,
Metlam Australia has your requirements covered.

Proudly Australian owned and
celebrating over 20 years in the market.

Metlam Australia Hand Dryers



It's time to discover the difference!

Celebrating over 20 years in operation, Metlam Australia is a proud wholly Australian-owned and managed company specialising in the manufacture of quality Commercial Washroom Accessories and Toilet Partition Hardware for the commercial, residential, hospitality, health, science, care, education, security and public facilities markets.

Our Hand Dryers

Metlam Australia has a range of fast, efficient, functional and cost-effective hand dryers for every project requirement. Our range includes elements of innovative Australian design and local assembly - from slimline contemporary designs through to ultra-efficient automatic high velocity drying. You can't go past Metlam Australia Hand Dryers to address any commercial washroom hand dryer requirements.

Our products are suitable for:



COMMERCIAL / INDUSTRIAL FACILITIES



HEALTH AND AGED CARE / RESEARCH FACILITIES



HOSPITALITY AND LEISURE FACILITIES



RESIDENTIAL FACILITIES



EDUCATIONAL FACILITIES



ACCESSIBLE COMPLIANT



PUBLIC FACILITIES



ML_IMC3_LUX

Integrated Mirror Cabinet – Includes Hand Dryer, Soap Dispenser & Paper Towel Dispenser

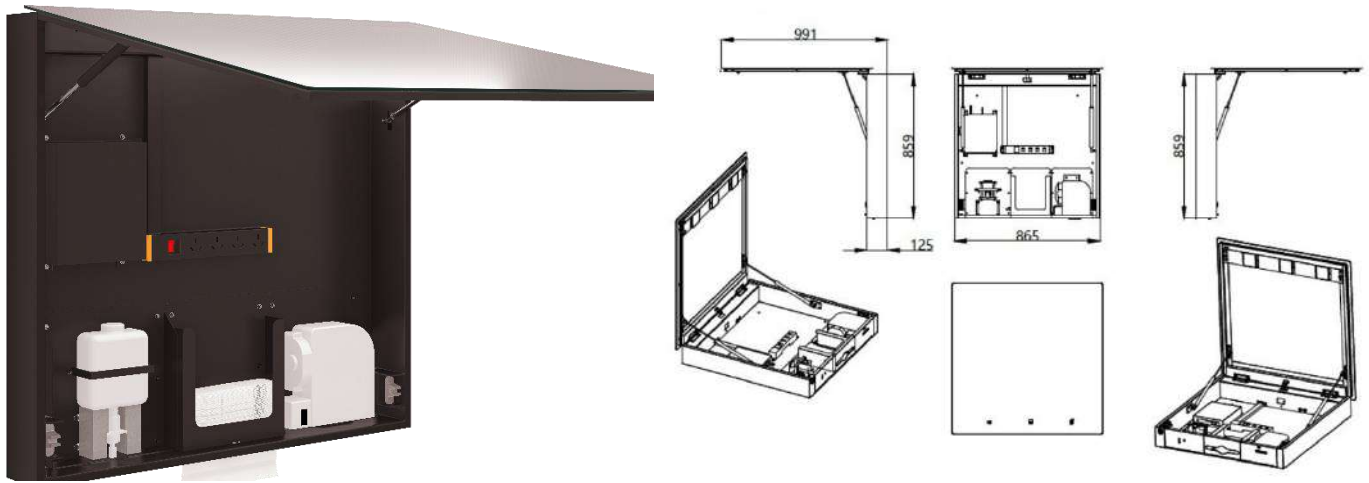

ML_IMC3_LUX SPECIFICATIONS

Material	1.2mm #304 Satin Stainless Steel
Hand Dryer	1000W, 220V-250V, Automatic Sensor Hand Dryer, 15-20 Seconds Drying Time. Hand Dryer is plugged into the Integrated Power Board.
Soap Dispenser	1000ml Automatic Sensor Soap Dispenser
Features	<p>Integrated Hand Dryer, Soap Dispenser and Paper Towel Dispenser.</p> <p>5mm Thick Frameless Glass.</p> <p>Sign of Function Indicator Light.</p> <p>Back-Lit Consumable Icons.</p> <p>Decorative Light Behind the Mirror.</p> <p>Tumbler Lock & Key.</p> <p>Mirror is supported by Twin-Damped Gas Springs.</p> <p>15 Amp Cord, Adaptor Included.</p>
Dimensions	859mmH x 865mmW x 125mmD
Warranty	3 year Warranty. Hand Dryer comes with Full Replacement Warranty



*Accessible compliant when installed in accordance with AS1428.1. guidelines.

Safety Approvals



ML_100N_SS

Slimline Automatic Operation Hand Dryer

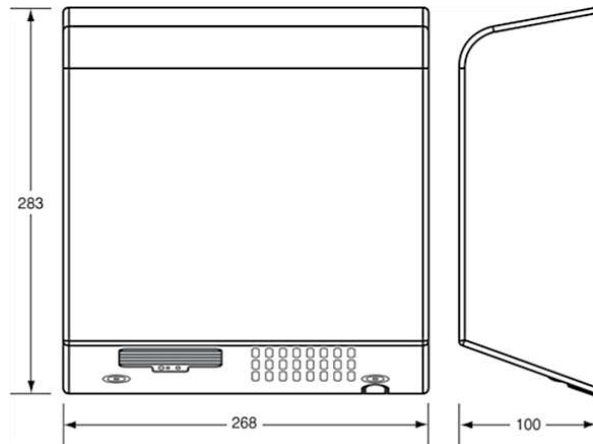

ML_100N_SS SPECIFICATIONS

Material	1.2mm #304 Satin Stainless Steel
Motor	1/4 HP, 7500 rpm, Brush Type, Dual Ball Bearings Motor, Thermal Protection-Auto Resetting Thermostat turns off at 105°C
Power Use	230-240 Vac, 50/60Hz, 2200-2400W
Sound Level	70db (+/-3)
Drying Time	Less than 15 seconds
DP Rating	IPX 1
Element	2200W @ 240VAC
Heater	87°C auto resetting thermostat, 141°C auto reset safety cut off
Warm Air	Output: 314.5m ³ /h (185 CFM), Temp: Ambient +20°C
Protection	60 sec power cut off, auto reset
Timing	2 sec delay turn off after last read
Sensor/Range	Adjustable, standard 18cm ± 2cm
Case Security	2 SS theft resistant hex drive screws (hex key supplied)
Net Weight	4.5kg
Dimensions	268mmW x 283mmH x 100mmD
Warranty	5 Years (3 Years Parts and Labour + 2 Years Parts only)
Note	Unit can be hard wired by electrician or used with cord and plug provided



*Accessible compliant when installed in accordance with AS1428.1. guidelines.

Safety Approvals



ML_ECLIPSE_DESIGNER

Slimline Automatic Operation Hand Dryer

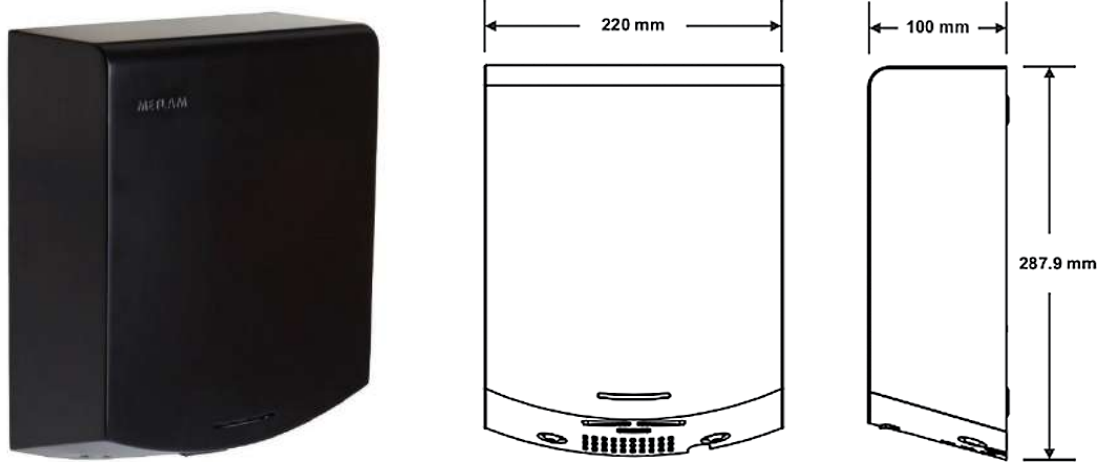

ML_ECLIPSE_DESIGNER SPECIFICATIONS

Material	1.2mm Designer Matte Black Powder Coat Steel
Features	Patented high-flow dual air outlets
Motor	250-500W Brush Type: Dual Ball Bearings, 16,000-29,000 RPM, 95°C auto reset overload
Power Use	220-240V, 50Hz, 1000W
Sound Level	72 DB (+-3) @1M
Drying Time	Less than 15 seconds
DP Rating	IP 24
Element	325 - 500W, adjustable
Heater	Auto resetting thermostat turns unit off at 85°C
Warm Air	Speed: 95-115m/s (adjustable), Temp: Ambient +25°
Protection	60 sec power cut off, auto reset
Sensor/Range	Infrared Automatic - 152mm +/-20mm preset, Blue LED indicates operation/range
Case Security	2 SS theft resistant hex drive screws (hex key supplied)
Net Weight	4.2kg
Dimensions	220mmW x 287.9mmH x 100mmD
Warranty	5 Years (3 Years Parts and Labour + 2 Years Parts only)
Note	Unit can be hard wired by electrician or used with cord and plug provided



*Accessible compliant when installed in accordance with AS1428.1. guidelines.

Safety Approvals



Green Certificates



ML_ECLIPSE05_SS

Slimline Automatic Operation Hand Dryer

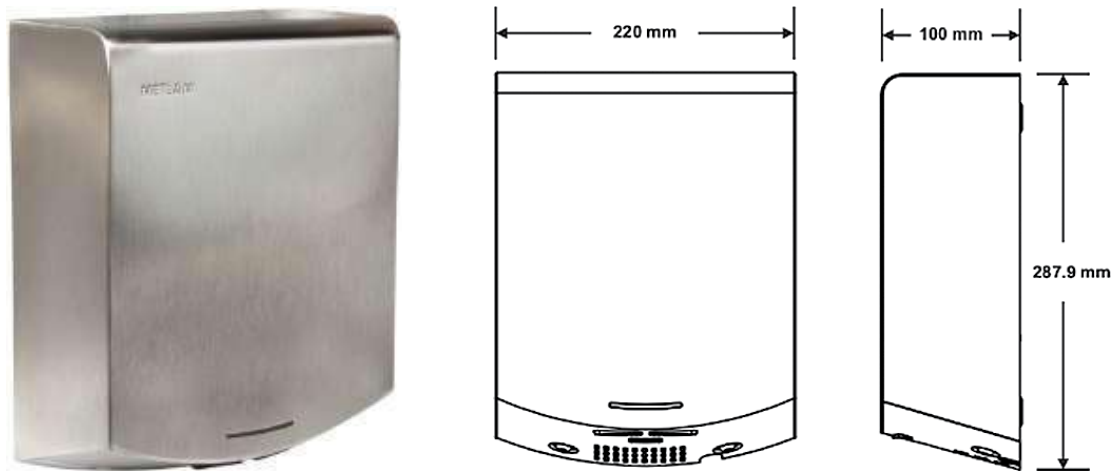

ML_ECLIPSE05_SS SPECIFICATIONS

Material	1.2mm #304 Satin Stainless Steel
Features	Patented high-flow dual air outlets
Motor	250-500W Brush Type: Dual Ball Bearings, 16,000-29,000 RPM, 95°C auto reset overload
Power Use	220-240V, 50Hz, 1000W
Sound Level	72 DB (+-3) @1M
Drying Time	Less than 15 seconds
DP Rating	IP 24
Element	325 - 500W, adjustable
Heater	Auto resetting thermostat turns unit off at 85°C
Warm Air	Speed: 95-115m/s (adjustable), Temp: Ambient +25°
Protection	60 sec power cut off, auto reset
Sensor/Range	Infrared Automatic - 152mm +/-20mm preset, Blue LED indicates operation/range
Case Security	2 SS theft resistant hex drive screws (hex key supplied)
Net Weight	4.2kg
Dimensions	220mmW x 287.9mmH x 100mmD
Warranty	5 Years (3 Years Parts and Labour + 2 Years Parts only)
Note	Unit can be hard wired by electrician or used with cord and plug provided



*Accessible compliant when installed in accordance with AS1428.1. guidelines.

Safety Approvals



Green Certificates



ML_ECLIPSE01_WHT

Slimline Automatic Operation Hand Dryer

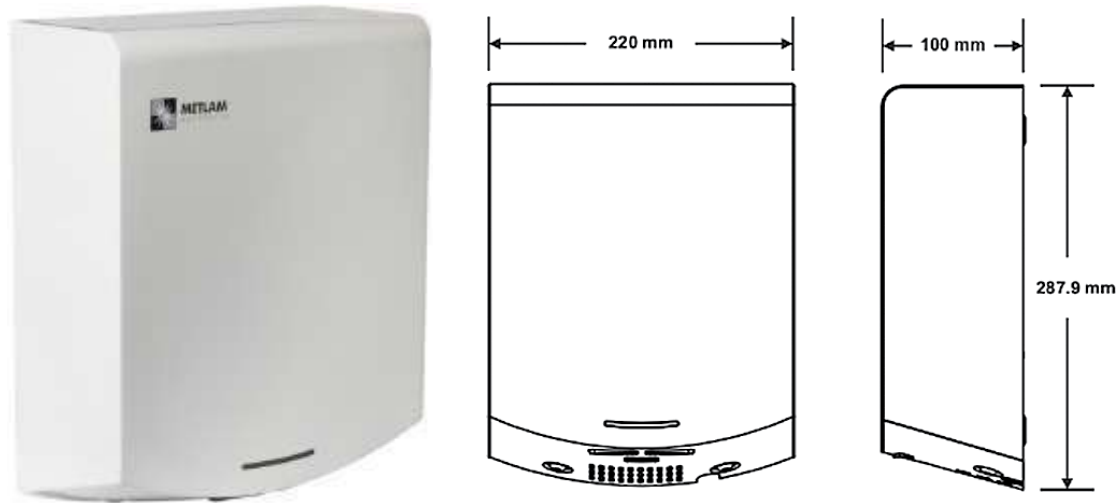

ML_ECLIPSE01_WHT SPECIFICATIONS

Material	1.2mm #304 White Powder Coat Steel
Features	Patented high-flow dual air outlets
Motor	250-500W Brush Type: Dual Ball Bearings, 16,000-29,000 RPM, 95°C auto reset overload
Power Use	220-240V, 50Hz, 1000W
Sound Level	72 DB (+-3) @1M
Drying Time	Less than 15 seconds
DP Rating	IP 24
Element	325 - 500W, adjustable
Heater	Auto resetting thermostat turns unit off at 85°C
Warm Air	Speed: 95-115m/s (adjustable), Temp: Ambient +25°C
Protection	60 sec power cut off, auto reset
Sensor/Range	Infrared Automatic - 152mm +/-20mm preset, Blue LED indicates operation/range
Case Security	2 SS theft resistant hex drive screws (hex key supplied)
Net Weight	4.2kg
Dimensions	220mmW x 287.9mmH x 100mmD
Warranty	5 Years (3 Years Parts and Labour + 2 Years Parts only)
Note	Unit can be hard wired by electrician or used with cord and plug provided



*Accessible compliant when installed in accordance with AS1428.1. guidelines.

Safety Approvals



Green Certificates



ML_ECOSLENDER_DESIGNER

Slimline Eco Automatic Operation Hand Dryer

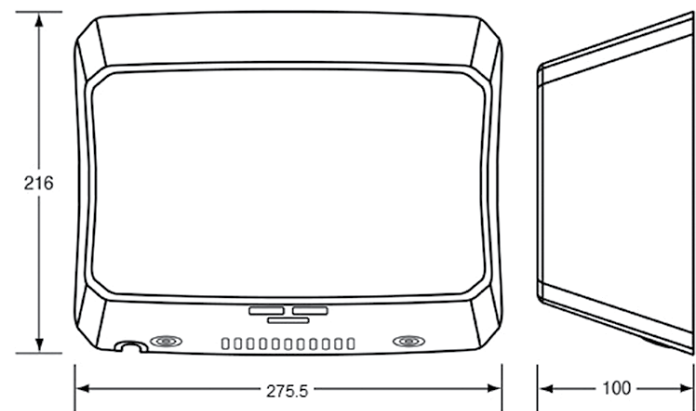

ML_ECOSLENDER_DESIGNER SPECIFICATIONS

Material	1.2mm Designer Matte Black Powder Coated Steel
Features	Contemporary curved design, Patented high-flow dual air outlets
Motor	Brush Type, Dual Ball Bearings, 16,000-29,000 RPM, 95°C auto reset overload
Power Use	240V, 50Hz, 1000W, 4.17A
Sound Level	68.9dB - 74.3dB (Adjustable)
Drying Time	Less than 15 seconds
DP Rating	IP 24
Element	325 - 500W, (Adjustable)
Heater	ON/OFF Heating Options, 85°C auto resetting thermostat, 142°C auto reset safety cut off
Warm Air	Speed: 45.5-70m/s (adjustable), Temp: Ambient +25°C
Protection	60 sec power cut off, auto reset
Sensor/Range	Infrared Automatic, Self Adjusting, 170mm+/-20mm, Blue LED indicates operation/range
Case Security	2 SS theft resistant hex drive screws (hex key supplied)
Net Weight	3.8kg
Dimensions	275.5mmW x 216mmH x 100mmD
Warranty	5 Years (3 Years Parts and Labour + 2 Years Parts only)
Note	Unit can be hard wired by electrician or used with cord and plug provided



*Accessible compliant when installed in accordance with AS1428.1. guidelines.

Safety Approvals



Green Certificates



ML_ECOSLENDER05_SS

Slimline Eco Automatic Operation Hand Dryer

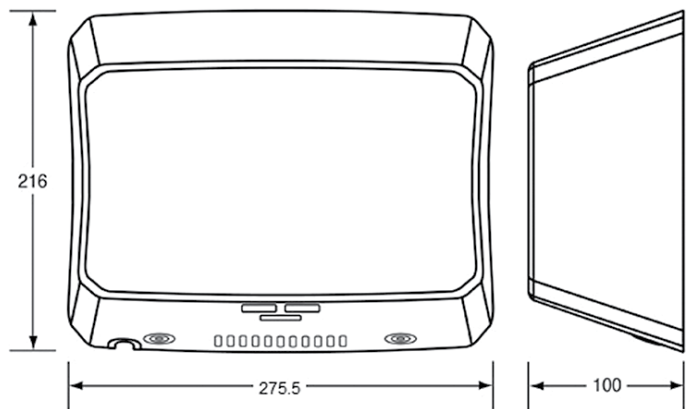

ML_ECOSLENDER05_SS SPECIFICATIONS

Material	1.2mm #304 Satin Stainless Steel
Features	Contemporary curved design, Patented high-flow dual air outlets
Motor	Brush Type, Dual Ball Bearings, 16,000-29,000 RPM, 95°C auto reset overload
Power Use	240V, 50Hz, 1000W, 4.17A
Sound Level	68.9dB - 74.3dB (Adjustable)
Drying Time	Less than 15 seconds
DP Rating	IP 24
Element	325 - 500W, (Adjustable)
Heater	ON/OFF Heating Options, 85°C auto resetting thermostat, 142°C auto reset safety cut off
Warm Air	Speed: 45.5-70m/s (adjustable), Temp: Ambient +25°C
Protection	60 sec power cut off, auto reset
Sensor/Range	Infrared Automatic, Self Adjusting, 170mm+/-20mm, Blue LED indicates operation/range
Case Security	2 SS theft resistant hex drive screws (hex key supplied)
Net Weight	3.8kg
Dimensions	275.5mmW x 216mmH x 100mmD
Warranty	5 Years (3 Years Parts and Labour + 2 Years Parts only)
Note	Unit can be hard wired by electrician or used with cord and plug provided



ML_ECOSLENDER01_WHT

Slimline Eco Automatic Operation Hand Dryer

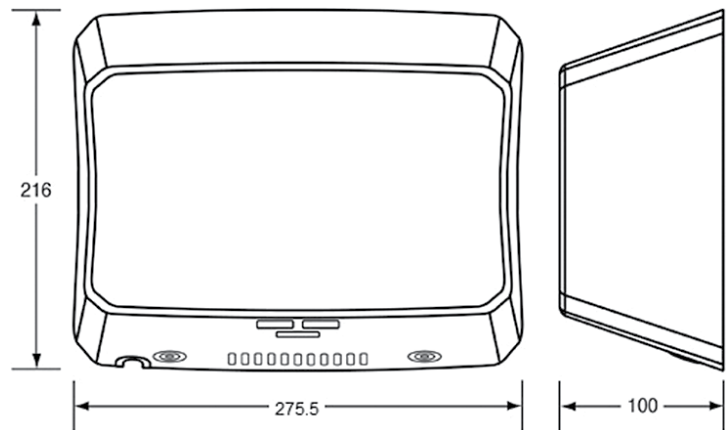

ML_ECOSLENDER01_WHT SPECIFICATIONS

Material	1.2mm #304 White Powder Coat Steel
Features	Contemporary curved design, Patented high-flow dual air outlets
Motor	Brush Type, Dual Ball Bearings, 16,000-29,000 RPM, 95°C auto reset overload
Power Use	240V, 50Hz, 1000W, 4.17A
Sound Level	68.9dB - 74.3dB (Adjustable)
Drying Time	Less than 15 seconds
DP Rating	IP 24
Element	325 - 500W, (Adjustable)
Heater	ON/OFF Heating Options, 85°C auto resetting thermostat, 142°C auto reset safety cut off
Warm Air	Speed: 45.5-70m/s (adjustable), Temp: Ambient +25°C
Protection	60 sec power cut off, auto reset
Sensor/Range	Infrared Automatic, Self Adjusting, 170mm+/-20mm, Blue LED indicates operation/range
Case Security	2 SS theft resistant hex drive screws (hex key supplied)
Net Weight	3.8kg
Dimensions	275.5mmW x 216mmH x 100mmD
Warranty	5 Years (3 Years Parts and Labour + 2 Years Parts only)
Note	Unit can be hard wired by electrician or used with cord and plug provided



*Accessible compliant when installed in accordance with AS1428.1. guidelines.

Safety Approvals



Green Certificates



ML_1800_WHT

Automatic Operation ABS Hand Dryer

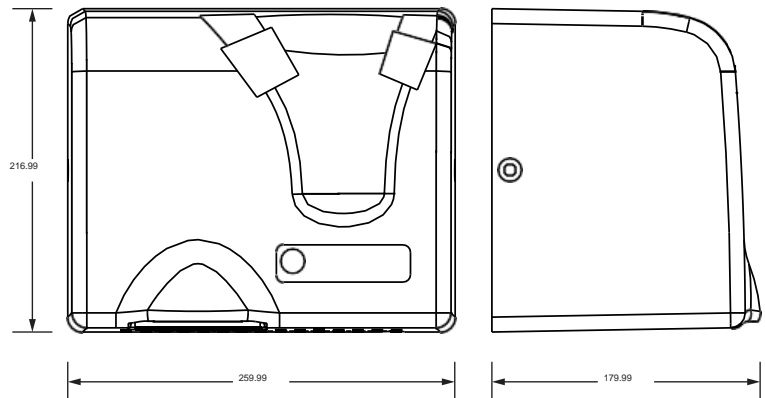

ML_1800_WHT SPECIFICATIONS

Casing	3.0mm White High-Grade Fire-Retardant ABS
Motor	80W Brushless, 2850 RPM, 105°C auto reset overload
Power Use	240V, 50Hz, 1800W, 7.50A
Sound Level	55db (+/- 3)
Drying Time	30-35 seconds
DP Rating	IPX 1
Heater	87°C auto resetting thermostat, 142°C auto reset safety cut off
Warm Air	Speed: 14.5m/s, Temp: Ambient +20°C
Protection	60 sec power cut off, auto reset
Timing	2 sec delay turn off after last read
Sensor/Range	Auto Infrared - 180mm +/-20mm preset, 100 - 300mm adjust
Case Security	2 SS theft resistant hex drive screws (hex key supplied)
Net Weight	3.5kg
Dimensions	259.99mmW x 216.99mmH x 179.99mmD
Warranty	5 Years (3 Years Parts and Labour + 2 Years Parts only)
Note	Unit can be hard wired by electrician or used with cord and plug provided



*Accessible compliant when installed in accordance with AS1428.1. guidelines.

Safety Approvals



Green Certificates





Warren Park Rugby League Stadium, NT



Optus Stadium, WA



Ashmore City Shopping Centre, QLD

ML_ECLIPSE_3N1REC_D

Recessed Paper Towel Dispenser,
Hand Dryer & Waste Receptacle

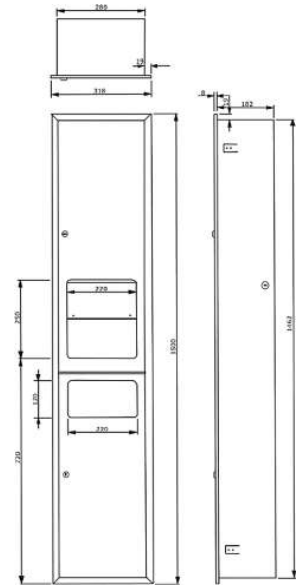

ML_ECLIPSE_3N1REC_D SPECIFICATIONS

Material/Finish	#304 Satin Stainless Steel
Features	Unit fitted with security lock, Seamless welds, rolled edges
Dispenser/ Option	300 Interfold paper towels, 500 Interleaved paper towels
Hand Dryer	Eclipse Auto Dryer
Warranty	5 Years (3 Years Parts and Labour + 2 Years Parts only)
Motor	250-500W Brush Type, Dual Ball Bearings, 29,000 RPM, 95°C auto reset overload
Power Use	240V, 50Hz, 1000W
Power Supply	Hard wired - 4 electrical cable entry points available
Drying Time	Less than 15 seconds
DP Rating	IP 24
Heater	85°C auto reset safety cut off
Warm Air	Speed: 70m/s, Temp: Ambient +25°C
Protection	60 sec power cut off, auto reset
Disposal	21L Removable Stainless Steel waste container
Overall Size	318mmW x 1500mmH x 190mmD
Wall Opening	290mmW x 1472mmH x 192mmD
Note	Unit is to be hard wired by licensed electrician, Unit is supplied with 2 keys



*Accessible compliant when installed in accordance with AS1428.1. guidelines.

Safety Approvals



Green Certificates



WEEE RoHS



ML_ECO_73N1REC

Recessed Paper Towel Dispenser,
Receptacle Hand Dryer & Waste

ML_ECO_73N1REC SPECIFICATIONS

Material/Finish	#304 Satin Stainless Steel
Features	Unit fitted with security lock, Full length piano hinge on doors, Seamless welds, rolled edges
Dispenser/Option	300 Interfold paper towels, 500 Interleaved paper towels
Hand Dryer	EcoFast Auto Dryer
Warranty	5 Years (3 Years Parts and Labour + 2 Years Parts only)
Motor	500W Brush Type: Dual Ball Bearings, 29,000RPM 105°C auto resetting safety overload thermostat
Power Use	240V, 50Hz, 1000W, 4.17A
Power Supply	Hard wired - 4 electrical cable entry points available
Drying Time	Less than 15 seconds
DP Rating	IPX1
Heater	85°C auto reset safety cut off
Warm Air	Speed: 90m/s, Temp: Ambient +30°C
Protection	60 sec power cut off, auto reset
Disposal	20L Removable Stainless Steel waste container
Overall Size	318mmW x 1625mmH x 141.5mmD
Wall Opening	290mmW x 1600mmH x 145mmD
Specify	Recessed
Note	Unit is to be hard wired by licensed electrician. Unit is supplied with 2 keys

ML ECO 73N1SM

Surface Mount Paper Towel
Dispenser, Receptacle Hand Dryer
& Waste

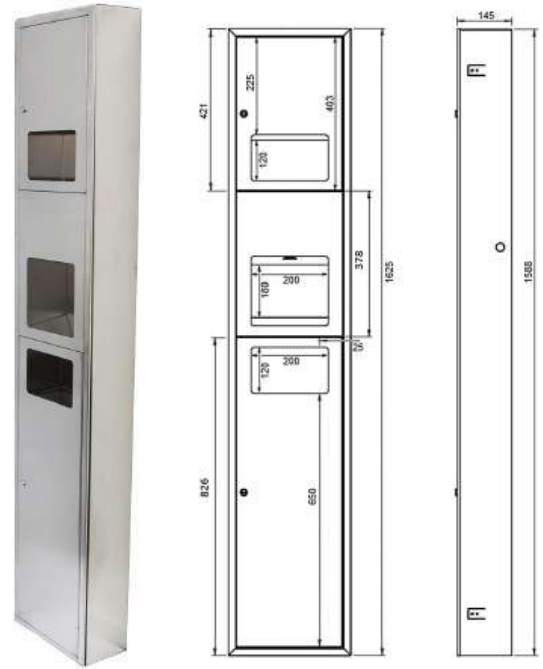

ML_ECO_73N1SM SPECIFICATIONS

Material/Finish	#304 Satin Stainless Steel
Features	Unit fitted with security lock, Full length piano hinge on doors, Seamless welds, rolled edges
Dispenser/ Option	300 Interfold paper towels / 500 Interleaved paper towels
Hand Dryer	Eco Auto Dryer
Warranty	5 Years (3 Years Parts and Labour + 2 Years Parts only)
Motor	500W Brush Type: Dual Ball Bearings, 29,000RPM 105°C auto resetting safety overload thermostat
Power Use	240V, 50Hz, 1000W, 4.17A
Power Supply	Hard wired - 4 electrical cable entry points available
Drying Time	Less than 15 seconds
DP Rating	IPX1
Heater	85°C auto reset safety cut off
Warm Air	Speed: 90m/s, Temp: Ambient +30°C
Protection	60 sec power cut off, auto reset
Disposal	20L Removable Stainless Steel waste container
Overall Size	318mmW x 1625mmH x 141.5mmD
Specify	Surface Mounted
Note	Unit is to be hard wired by licensed electrician. Unit is supplied with 2 keys



Optus Stadium, WA



Maryborough Highland Society, VIC



Hotel Esplanade, VIC

Our Hand Dryers have been used in countless projects across market segments throughout Australasia.

Metlam Australia has a Hand Dryer solution for every project and budget.



Martial Arts Centre, Liverpool NSW



Waikerie Recreation Centre, SA



Melbourne Recital Centre, VIC



The Lights Community and Sports Centre, SA



McDonalds, South Melbourne Vic



146 Marsden Street, Parramatta NSW



METLAM
AUSTRALIA

For Further information on Metlam Australia's product range please contact us at:

HEAD OFFICE

17 Parkers Road New Gisborne, Vic 3438
Tel: 1300 METLAM (1300 638 526)
Email: sales@metlam.com.au

NSW (Incorporating ACT)

Sydney Branch
Unit 23, 66 Turner Road Smeaton Grange, NSW 2567
Tel: 02 8778 8801
Email: nswsales@metlam.com.au
Email: actsales@metlam.com.au

QUEENSLAND

Brisbane Branch
Shop 2, 57-59 Rosemount Terrace Windsor QLD, 4030
Tel: 07 3247 0200
Email: qldsales@metlam.com.au

VICTORIA (Incorporating TAS)

Melbourne Branch
22 Gallivan Road New Gisborne, 3438
Tel: 03 5420 8800
Email: vicsales@metlam.com.au
Email: tassales@metlam.com.au

WESTERN AUSTRALIA

Perth Branch
Unit 1, 5 Bramall Street East Perth, WA 6004
Tel: 08 6250 2601
Email: wasales@metlam.com.au

SOUTH AUSTRALIA & NORTHERN TERRITORY

Adelaide, South Australia
Tel: 0407 553 045
Email: sasales@metlam.com.au
Email: ntsales@metlam.com.au

NEW ZEALAND

Head Office
17 Parkers Road New Gisborne, Vic 3438
Tel: 0407 863 730
Email: sales@metlam.com.au

INTERNATIONAL SALES

Head Office
17 Parkers Road New Gisborne, Vic 3438
Tel: 1300 METLAM (1300 638 526)
Email: sales@metlam.com.au

The technical recommendations contained in this document are necessarily of a general nature and should not be relied on for specific applications without first securing competent advice. Whilst Metlam Australia Pty Ltd has taken all reasonable steps to ensure the information contained herein is accurate and current, it does not warrant the accuracy or completeness of the information and does not accept liability for errors or omissions. Any commercial product should only be installed by a competent tradesperson and serviced/maintained by knowledgeable janitorial staff or competent people. Metlam Australia accepts no responsibility for any damage to product, walls or fixtures due to incorrect installation or maintenance of any of their products